

AIR FILTERS FOR ECLIPSE BLOWERS

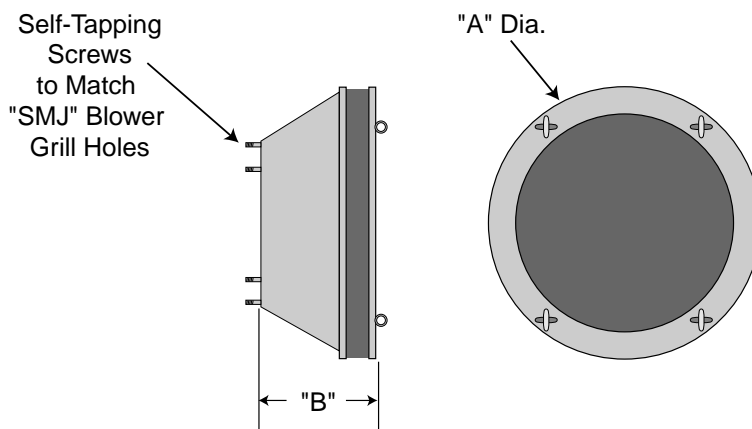

- Filters dust and dirt from combustion air.
- Keeps blower wheels free of dirt for greatest efficiency and capacity; reduces blower, mixer, and burner maintenance.
- Mounts in place of standard grill on Eclipse SMJ blowers.
- Easy filter element replacement.

Specifications



Catalog Number	Assembly Number	Maximum Capacity CFH	Blower Inlet Size	Dimensions In Inches		Element Part Number
				A	B	
25 FAJ-S	200758	25,000	4"	15-7/8	6-1/2	11132
25 FAJ-M	200757	25,000	6" & 8"	15-7/8	6-1/2	11132
50 FAJ	200756	50,000	6" & 8"	20-1/8	6-1/2	11128
150 FAJ-S	200754	150,000	6" & 8"	26-7/8	7-3/4	15608
150 FAJ-M	200755	150,000	10" & 12"	26-7/8	7-3/4	15608
250 FAJ-L	200753	250,000	10" & 12"	27-7/8	17-7/8	*

* Requires two elements: #15608 and #10411



Eclipse Combustion



Offered By:

Power Equipment Company
2011 Williamsburg Road
Richmond, Virginia 23231
Phone (804) 236-3800
Fax (804) 236-3882

www.peconet.com